

CAD FILE:

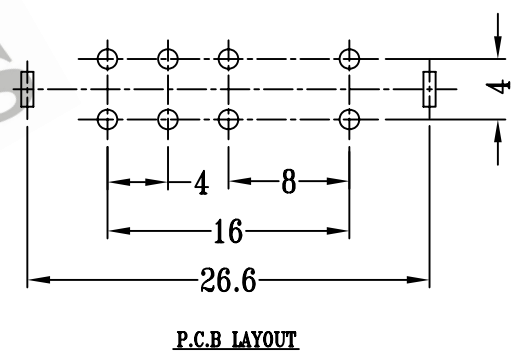
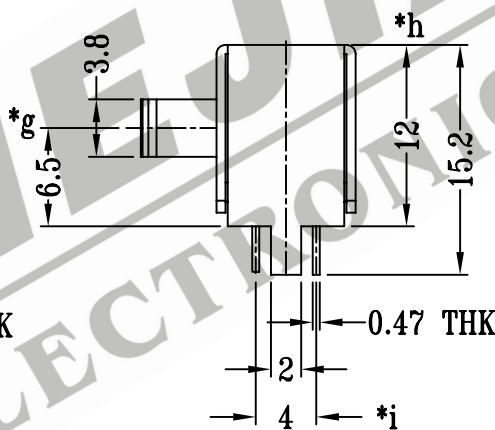
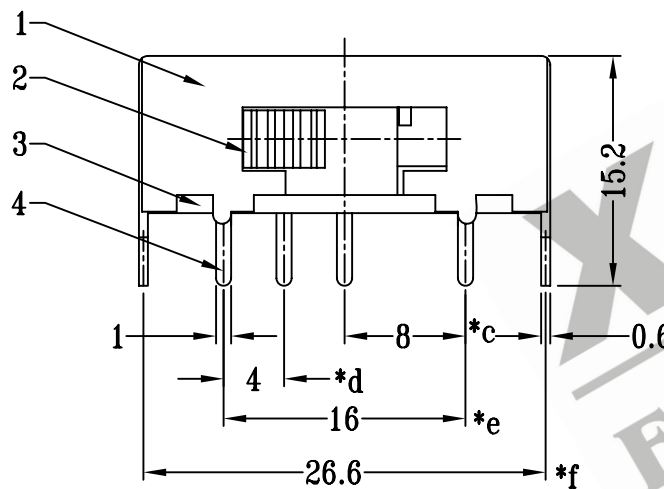
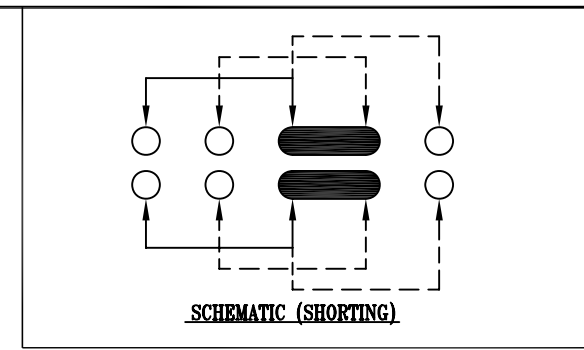
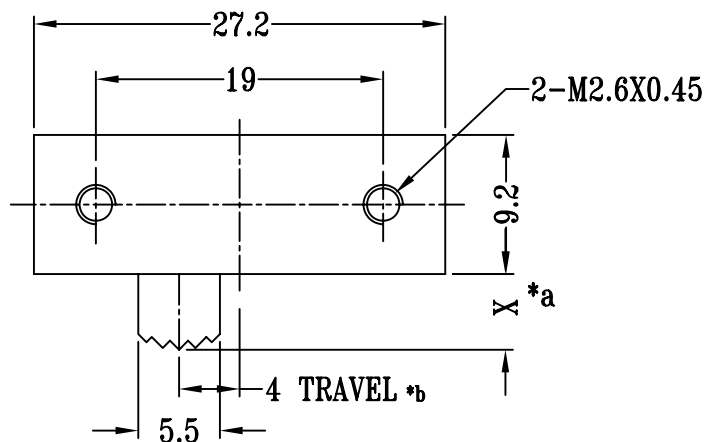

注:带\*表示关键尺寸(9个)

NO.	PARTS	MATERIALS	Q'TY	FINISH	TOLERANCE UNLESS SPECIFIED	SHENZHEN XIEJIA ELECTRONICS CO.,LTD.					
8						ISSUE		DATE		DESCRIPTIONS OF REVISION	APPD.
7	CONTACT CLIP	PBS STRIP	2	Ag PLATED	WITHIN: 1.5 ±0.1mm OVER: 1.5 ±0.2mm	TITLE : HORIZONTAL SLIDE SWITCH		UNIT : mm	DRWG NO.: XJ-DR-SK23H01-00		
6	SPRING	STEEL WIRE	1	TEMPER		MODEL: SK-23H01		SCALE: 2:1	DWN.	ZHOUYU	2006-11-30
5	STEEL BALL	STEEL	1	NATURAL		ALL MATERIALS MUST BE COMPLIANT TO ROHS			CHK'D	FANGYING	2006-11-30
4	TERMINAL	BRASS STRIP	8	Ag PLATED OVER Ni PLATED					APPD.	KANGXINAN	2006-11-30
3	BASE	PHENOLIC RESIN	1	BLACK							
2	KNOB	POM	1	BLACK							
1	FRAME	STEEL STRIP	1	Ni PLATED							